



# Augusta County, Virginia

## Request for Quotes

---

**Date:** December 21, 2021

**Project Title:** Augusta County Government Center – Security Improvements  
**Project No. :** 12010-21-01

**Project Location:** Augusta County Government Center  
18 Government Center Lane  
Verona, VA 24482

**Questions or Pre-Quote Meeting:** Candy Hensley, Project Manager  
Call: 540-245-5610  
Email: [chensley@co.augusta.va.us](mailto:chensley@co.augusta.va.us)

**Quote Deadline:** 2:00PM, January 20, 2022  
Please deliver to:  
Elana Sorrell, Senior Purchasing Assistant  
County of Augusta  
18 Government Center Lane  
Verona, VA 24482  
[esorrell@co.augusta.va.us](mailto:esorrell@co.augusta.va.us)  
Fax: 540-245-5741

**GENERAL:** The County of Augusta is seeking a Class A Contractor to complete improvements in accordance with the approved plans titled Security Improvements, which will occur at Augusta County Government Center in Verona, VA.

**REQUIREMENTS:**

The Contractor shall furnish all labor, supervision, equipment, tools, parts and materials, as necessary to complete all aspects of this project.

**DESCRIPTION:**

The project consists of installing a window with pass through at the IT Department public counter, ballistic paneling under the counter, and installation of three metal doors, one each at the Registrar's Office, the Security Office and the Board Room.

**SCOPE OF WORK:**

1. All work shall be performed in accordance with the project drawing and specifications.
2. Work is to be performed in accordance with applicable rules, regulations, codes, and ordinances of local, state, and federal authorities. Obtain any necessary permits from the Building Inspection Department of the County of Augusta. Note that there are no permit fees for work on County owned buildings. Request inspections and provide inspection results, as required.
3. All work is to be done as per OSHA safety guidelines.

4. Staging area and size to be determined during a pre-construction meeting with the Owner and the Contractor awarded the project.
5. The building and its contents shall be protected against all risks, and any damages shall be repaired or replaced at no cost to the County.
6. Debris from this project may be taken to the Augusta Regional Landfill. Disposal fees will be waived for this project. The dumpster on site cannot be used.
7. Remove and clean up any debris related to the project daily.
8. Contractor is responsible for submitting all specifications and warranty information to the County.
9. The contractor shall communicate with the project manager or other designated individual of reporting progress, problems or otherwise expediting the work in a timely fashion.
10. The contractor may utilize toilet facilities on premise.
11. Work is to be conducted between 7:30 AM and 6:00 PM. Work outside these hours shall be arranged through the Project Manager.
12. The contractor shall secure all materials and tools left on site. The County will not be responsible for theft or damage that occurs. The contractor shall take all necessary precautions.
13. The contractor will be required to install a temporary barrier at the IT Counter between when the existing metal gate is removed and when the new window barrier is installed at the end of each day.

#### **Request For Quote Preparation and Submission Requirements**

- A. Bids must be submitted before due date and time at the location listed on page 1. Late bids will not be accepted.
- B. Each bid must give the complete legal name and full business address of the bidder. Erasures or other changes in a bid must be explained or noted over the signature of the bidder. Bids containing any conditions, omissions, unexplained erasures, alterations or items not called for in the proposal, or irregularities of any kind, may be rejected by the County as being incomplete or non-responsive. The RFQ number should be clearly noted on the outside of the envelope or box. No responsibility will be attached to any County agent for the premature opening of a bid not properly addressed and identified. Failure to submit all information requested may result in the purchasing agent requiring prompt submission of missing information. Mandatory requirements are those required by law or regulation or are such that they cannot be waived and are not subject to negotiation.

- C. The bidder shall place on the outside of the envelope containing the bid and shall place in the bid over his signature whichever of the following notations is appropriate and insert his Contractor license/registration number:

Licensed Class \_\_\_ (A or B) Virginia Contractor No. \_\_\_\_\_

If the bidder fails to provide this information on his bid or on the envelope containing the bid and fails to promptly provide said Contractor license number to the County in writing when requested to do so before or after the opening of bids, he shall be deemed to be in violation of Section 54.1-1112 of the Code of Virginia (1950), as amended, and his bid will not be considered.

The bidder must also place its Employer Identification Number (SSN or EIN) within the bid.

- D. As used in this RFQ, the terms "must," "shall," "should" and "may" identify the criticality of requirements. "Must" and "shall" identify requirements whose absence will have a major negative impact on the suitability of the proposed solution. Items labeled as "should" or "may" are highly desirable, although their absence will not have a large impact and would be useful, but are not necessary. Depending on the overall response to the RFQ, some individual "must" and "shall" items may not be fully satisfied, but it is the intent to satisfy most, if not all, "must" and "shall" requirements. The inability of an offeror to satisfy a "must" or "shall" requirement does not automatically remove that offeror from consideration; however, it may seriously affect the overall rating of the offerors' proposal.
- E. Ownership of all data, materials, and documentation originated and prepared for the County pursuant to the RFQ shall belong exclusively to the County and be subject to public inspection in accordance with the Virginia Freedom of Information Act. Trade secrets or proprietary information submitted by an offeror shall not be subject to public disclosure under the Virginia Freedom of Information Act; however, the offeror must invoke the protections of § 2.2-4342F of the Code of Virginia, in writing, either before or at the time the data or other material is submitted. The written notice must specifically identify the data or materials to be protected and state the reasons why protection is necessary. The proprietary or trade secret material submitted must be identified by some distinct method such as highlighting or underlining and must indicate only the specific words, figures, or paragraphs that constitute trade secret or proprietary information. The classification of an entire proposal document, line item prices, and/or total proposal prices as proprietary or trade secrets is not acceptable and will result in rejection of the proposal.
- F. The County reserves the right to reject any and all bids and to waive any informality of technical defects if, in its judgement, the best interest of the County will be served as specified in Virginia Code § 2.2-4319.

## **List of Technical Specifications**

08 11 13 Hollow Metal Doors and Frames

08 56 53 Security Windows

09 25 00 Gypsum Board

09 51 13 Acoustical Panel Ceilings

09 91 00 Painting

10 26 41 Bullet Resistant Panels

13 90 00 Common Work Results for Fire Suppression

## HOLLOW METAL DOORS AND FRAMES – SECTION 08 11 13

### PART ONE GENERAL

#### 1.1 RELATED DOCUMENTS

- A. Drawings and general provisions of the Contract, including General and Supplementary Conditions and Division 01 Specification Sections, apply to this Section.

#### 1.2 SUMMARY

- A. Related Sections:
  - 1. None

#### 1.3 DEFINITIONS

- A. Minimum Thickness: Minimum thickness of base metal without coatings according to NAAMM-HMMA 803 or SDI A250.8.

#### 1.4 COORDINATION

- A. Coordinate anchorage installation for hollow-metal frames. Furnish setting drawings, templates, and directions for installing anchorages, including sleeves, concrete inserts, anchor bolts, and items with integral anchors. Deliver such items to Project site in time for installation.

#### 1.5 ACTION SUBMITTALS

- A. Product Data: For each type of product.
  - 1. Include construction details, material descriptions, core descriptions, and finishes.
- B. Shop Drawings: Include the following:
  - 1. Elevations of each door type.
  - 2. Details of doors, including vertical- and horizontal-edge details and metal thicknesses.
  - 3. Frame details for each frame type, including dimensioned profiles and metal thicknesses.
  - 4. Locations of reinforcement and preparations for hardware.
  - 5. Details of each different wall opening condition.
  - 6. Details of anchorages, joints, field splices, and connections.
  - 7. Details of accessories.
  - 8. Details of moldings, removable stops, and glazing.
  - 9. Details of conduit and preparations for power, signal, and control systems.
- C. Samples for Initial Selection: For units with factory-applied color finishes.
- D. Samples for Verification:
  - 1. For each type of exposed finish required, prepared on Samples of not less than 3 by 5 inches.
  - 2. For "Doors" and "Frames" subparagraphs below, prepare Samples approximately 12 by 12 inches to demonstrate compliance with requirements for quality of materials and construction:
    - a. Doors: Show vertical-edge, top, and bottom construction; core construction; and hinge and other applied hardware reinforcement. Include separate section showing glazing if applicable.

- b. Frames: Show profile, corner joint, floor and wall anchors, and silencers. Include separate section showing fixed hollow-metal panels and glazing if applicable.
- F. Schedule: Provide a schedule of hollow-metal work prepared by or under the supervision of supplier, using same reference numbers for details and openings as those on drawings. Coordinate with final Door Hardware Schedule.

## 1.6 INFORMATIONAL SUBMITTALS

- A. Product Test Reports: For each type of hollow-metal door and frame assembly, for tests performed by a qualified testing agency.
- B. Oversize Construction Certification: For assemblies required to be fire rated and exceeding limitations of labeled assemblies.

## 1.7 DELIVERY, STORAGE, AND HANDLING

- A. Deliver hollow-metal work palletized, packaged, or crated to provide protection during transit and Project-site storage. Do not use non-vented plastic.
  - 1. Provide additional protection to prevent damage to factory-finished units.
- B. Deliver welded frames with two removable spreader bars across bottom of frames, tack welded to jambs and mullions.
- C. Store hollow-metal work vertically under cover at Project site with head up. Place on minimum 4-inch-high wood blocking. Provide minimum 1/4-inch space between each stacked door to permit air circulation.

## PART TWO PRODUCTS

### 2.1 MANUFACTURERS

- A. Manufacturers: Subject to compliance with requirements, available manufacturers offering products that may be incorporated into the Work include, but are not limited to, the following:
  - 1. Ceco Door Products; an Assa Abloy Group company.
  - 2. Republic Doors and Frames.
  - 3. Steelcraft; an Ingersoll-Rand company.
  - 4. Substitutions: Permitted

### 2.2 REGULATORY REQUIREMENTS

- A. Fire-Rated Assemblies: Complying with NFPA 80 and listed and labeled by a qualified testing agency acceptable to authorities having jurisdiction for fire-protection ratings and temperature-rise limits indicated, based on testing at positive pressure according to NFPA 252 or UL 10C.
  - 1. Smoke- and Draft-Control Assemblies: Provide an assembly with gaskets listed and labeled for smoke and draft control by a qualified testing agency acceptable to authorities having jurisdiction, based on testing according to UL 1784 and installed in compliance with NFPA 105.
- B. Fire-Rated, Borrowed-Light Assemblies: Complying with NFPA 80 and listed and labeled by a testing and inspecting agency acceptable to authorities having jurisdiction for fire-protection ratings indicated, based on testing according to NFPA 257 or UL 9.

## 2.3 INTERIOR DOORS AND FRAMES

- A. Construct interior doors and frames to comply with the standards indicated for materials, fabrication, hardware locations, hardware reinforcement, tolerances, and clearances, and as specified. Door frames and doors shall be galvanized in wet locations and as directed by the Owner. Minimum thickness of face sheet gauge is prior to galvanizing, where galvanizing is indicated.
- B. Heavy-Duty Doors and Frames: SDI A250.8, Level 2. At locations indicated in the Door and Frame Schedule.
  - 1. Physical Performance: Level B according to SDI A250.4.
  - 2. Doors:
    - a. Type: As indicated in the Door and Frame Schedule.
    - b. Thickness: 1-3/4 inches.
    - c. Face: Uncoated, cold-rolled steel sheet, minimum thickness of 0.042 inch, 18-gauge face sheets.
    - d. Edge Construction: Model 2, Seamless.
    - e. Core: Manufacturer's standard kraft-paper honeycomb, polystyrene, polyurethane, polyisocyanurate, mineral-board, or vertical steel-stiffener core at manufacturer's discretion.
  - 3. Frames:
    - a. Materials: Uncoated steel sheet, minimum thickness of 0.053 inch.
    - b. Construction: Full profile welded.
  - 4. Exposed Finish: Prime.

## 2.4 HOLLOW-METAL PANELS

- A. Provide hollow-metal panels of same materials, construction, and finish as adjacent door assemblies.

## 2.5 FRAME ANCHORS

- A. Jamb Anchors:
  - 1. Masonry Type: Adjustable strap-and-stirrup or T-shaped anchors to suit frame size, not less than 0.042 inch thick, with corrugated or perforated straps not less than 2 inches wide by 10 inches long; or wire anchors not less than 0.177 inch thick.
  - 2. Stud-Wall Type: Designed to engage stud, welded to back of frames; not less than 0.042 inch thick.
  - 3. Compression Type for Drywall Slip-on Frames: Adjustable compression anchors.
  - 4. Post-installed Expansion Type for In-Place Concrete or Masonry: Minimum 3/8-inch diameter bolts with expansion shields or inserts. Provide pipe spacer from frame to wall, with throat reinforcement plate, welded to frame at each anchor location.
- B. Floor Anchors: Formed from same material as frames, minimum thickness of 0.042 inch, and as follows:
  - 1. Monolithic Concrete Slabs: Clip-type anchors, with two holes to receive fasteners.
  - 2. Separate Topping Concrete Slabs: Adjustable-type anchors with extension clips, allowing not less than 2 inch height adjustment. Terminate bottom of frames at finish floor surface.

## 2.6 MATERIALS

- A. Recycled Content of Steel Products: Post consumer recycled content plus one-half of pre-consumer recycled content not less than 23 percent.
- B. Cold-Rolled Steel Sheet: ASTM A 1008/A 1008M, Commercial Steel (CS), Type B; suitable for exposed applications.
- C. Hot-Rolled Steel Sheet: ASTM A 1011/A 1011M, Commercial Steel (CS), Type B; free of scale, pitting, or surface defects; pickled and oiled.
- D. Metallic-Coated Steel Sheet: ASTM A 653/A 653M, Commercial Steel (CS), Type B.
- E. Frame Anchors: ASTM A 879/A 879M, Commercial Steel (CS), 04Z coating designation; mill phosphatized.
  - 1. For anchors built into exterior walls, steel sheet complying with ASTM A 1008/A 1008M or ASTM A 1011/A 1011M, hot-dip galvanized according to ASTM A 153/A 153M, Class B.
- F. Inserts, Bolts, and Fasteners: Hot-dip galvanized according to ASTM A 153/A 153M.
- G. Power-Actuated Fasteners in Concrete: Fastener system of type suitable for application indicated, fabricated from corrosion-resistant materials, with clips or other accessory devices for attaching hollow-metal frames of type indicated.
- H. Grout: ASTM C 476, except with a maximum slump of 4 inches, as measured according to ASTM C 143/C 143M.
- I. Mineral-Fiber Insulation: ASTM C 665, Type I (blankets without membrane facing); consisting of fibers manufactured from slag or rock wool; with maximum flame-spread and smoke developed indexes of 25 and 50, respectively; passing ASTM E 136 for combustion characteristics.
- J. Bituminous Coating: Cold-applied asphalt mastic, compounded for 15-mil dry film thickness per coat. Provide inert-type noncorrosive compound free of asbestos fibers, sulfur components, and other deleterious impurities.

## 2.7 FABRICATION

- A. Fabricate hollow-metal work to be rigid and free of defects, warp, or buckle. Accurately form metal to required sizes and profiles, with minimum radius for metal thickness. Where practical, fit and assemble units in manufacturer's plant. To ensure proper assembly at Project site, clearly identify work that cannot be permanently factory assembled before shipment.
- B. Hollow-Metal Doors:
  - 1. Steel-Stiffened Door Cores: Provide minimum thickness 0.026 inch, steel vertical stiffeners of same material as face sheets extending full-door height, with vertical webs spaced not more than 6 inches apart. Spot weld to face sheets no more than 5 inches o.c. Fill spaces between stiffeners with glass- or mineral-fiber insulation.
  - 2. Fire Door Cores: As required to provide fire-protection and temperature-rise ratings indicated.
  - 3. Vertical Edges for Single-Acting Doors: Bevel edges 1/8 inch in 2 inches

4. Top Edge Closures: Close top edges of doors with flush closures of same material as face sheets.
  5. Bottom Edge Closures: Close bottom edges of doors where required for attachment of weather stripping with end closures or channels of same material as face sheets.
  6. Exterior Doors: Provide weep-hole openings in bottoms of exterior doors to permit moisture to escape. Seal joints in top edges of doors against water penetration.
  7. Astragals: Provide overlapping astragal on one leaf of pairs of doors where required by NFPA 80 for fire-performance rating or where indicated. Extend minimum 3/4 inch beyond edge of door on which astragal is mounted or as required to comply with published listing of qualified testing agency.
- C. Hollow-Metal Frames: Where frames are fabricated in sections due to shipping or handling limitations, provide alignment plates or angles at each joint, fabricated of same thickness metal as frames.
1. Provide countersunk, flat- or oval-head exposed screws and bolts for exposed fasteners unless otherwise indicated.
  2. Grout Guards: Weld guards to frame at back of hardware mortises in frames to be grouted.
  3. Floor Anchors: Weld anchors to bottoms of jambs with at least four spot welds per anchor; however, for slip-on drywall frames, provide anchor clips or countersunk holes at bottoms of jambs.
  4. Jamb Anchors: Provide number and spacing of anchors as follows:
    - a. Masonry Type: Locate anchors not more than 16 inches from top and bottom of frame. Space anchors not more than 32 inches o.c., to match coursing, and as follows:
      - 1) Two anchors per jamb up to 60 inches high.
      - 2) Three anchors per jamb from 60 to 90 inches high.
      - 3) Four anchors per jamb from 90 to 120 inches high.
      - 4) Four anchors per jamb plus one additional anchor per jamb for each 24 inches or fraction thereof above 120 inches high.
    - b. Stud-Wall Type: Locate anchors not more than 18 inches from top and bottom of frame. Space anchors not more than 32 inches o.c. and as follows:
      - 1) Three anchors per jamb up to 60 inches high.
      - 2) Four anchors per jamb from 60 to 90 inches high.
      - 3) Five anchors per jamb from 90 to 96 inches high.
      - 4) Five anchors per jamb plus one additional anchor per jamb for each 24 inches or fraction thereof above 96 inches high.
    - c. Compression Type: Not less than two anchors in each frame.
    - d. Post installed Expansion Type: Locate anchors not more than 6 inches from top and bottom of frame. Space anchors not more than 26 inches o.c.
  5. Head Anchors: Two anchors per head for frames more than 42 inches wide and mounted in metal-stud partitions.
  6. Door Silencers: Except on weather-stripped frames, drill stops to receive door silencers as follows. Keep holes clear during construction.
    - a. Single-Door Frames: Drill stop in strike jamb to receive three door silencers.
    - b. Double-Door Frames: Drill stop in head jamb to receive two door silencers.
- D. Fabricate concealed stiffeners and edge channels from either cold- or hot-rolled steel sheet.
- E. Hardware Preparation: Factory prepare hollow-metal work to receive templated mortised

hardware; include cutouts, reinforcement, mortising, drilling, and tapping according to SDI A250.6, the Door Hardware Schedule, and templates.

1. Reinforce doors and frames to receive nontemplated, mortised, and surface-mounted door hardware.
2. Comply with applicable requirements in SDI A250.6 and BHMA A156.115 for preparation of hollow-metal work for hardware.

F. Stops and Moldings: Provide stops and moldings around glazed lites and louvers where indicated. Form corners of stops and moldings with [butted] [or] [mitered] hairline joints.

1. Single Glazed Lites: Provide fixed stops and moldings welded on secure side of hollow metal work.
2. Multiple Glazed Lites: Provide fixed and removable stops and moldings so that each glazed lite is capable of being removed independently.
3. Provide fixed frame moldings on outside of exterior and on secure side of interior doors and frames.
4. Provide loose stops and moldings on inside of hollow-metal work.
5. Coordinate rabbet width between fixed and removable stops with glazing and installation types indicated.

## 2.8 STEEL FINISHES

A. Prime Finish: Clean, pretreat, and apply manufacturer's standard primer.

1. Shop Primer: Manufacturer's standard, fast-curing, lead- and chromate-free primer complying with SDI A250.10; recommended by primer manufacturer for substrate; compatible with substrate and field-applied coatings despite prolonged exposure.

B. Factory Finish: Clean, pretreat, and apply manufacturer's standard two-coat, baked-on finish consisting of prime coat and thermosetting topcoat, complying with SDI A250.3.

1. Color and Gloss: As selected by Architect.

## PART THREE - EXECUTION

### 3.1 EXAMINATION

- A. Examine substrates, areas, and conditions, with Installer present, for compliance with requirements for installation tolerances and other conditions affecting performance of the work.
- B. Examine roughing-in for embedded and built-in anchors to verify actual locations before frame installation.
- C. Prepare written report, endorsed by Installer, listing conditions detrimental to performance of the work.
- D. Proceed with installation only after unsatisfactory conditions have been corrected.

### 3.2 PREPARATION

- A. Remove welded-in shipping spreaders installed at factory. Restore exposed finish by grinding, filling, and dressing, as required to make repaired area smooth, flush, and invisible on exposed faces.
- B. Drill and tap doors and frames to receive nontemplated, mortised, and surface-mounted door hardware.

### 3.3 INSTALLATION

- A. General: Install hollow-metal work plumb, rigid, properly aligned, and securely fastened in place. Comply with Drawings and manufacturer's written instructions.
- B. Hollow-Metal Frames: Install hollow-metal frames of size and profile indicated. Comply with SDI A250.11 or NAAMM-HMMA 840 as required by standards specified.
1. Set frames accurately in position; plumbed, aligned, and braced securely until permanent anchors are set. After wall construction is complete, remove temporary braces, leaving surfaces smooth and undamaged.
    - a. At fire-rated openings, install frames according to NFPA 80.
    - b. Where frames are fabricated in sections because of shipping or handling limitations, field splice at approved locations by welding face joint continuously; grind, fill, dress, and make splice smooth, flush, and invisible on exposed faces.
    - c. Install frames with removable stops located on secure side of opening.
    - d. Install door silencers in frames before grouting.
    - e. Remove temporary braces necessary for installation only after frames have been properly set and secured.
    - f. Check plumb, square, and twist of frames as walls are constructed. Shim as necessary to comply with installation tolerances.
    - g. Field apply bituminous coating to backs of frames that will be filled with grout containing anti-freezing agents.
  2. Floor Anchors: Provide floor anchors for each jamb and mullion that extends to floor, and secure with post-installed expansion anchors.
    - a. Floor anchors may be set with power-actuated fasteners instead of post-installed expansion anchors if so indicated and approved on shop drawings.
  3. Metal-Stud Partitions: Solidly pack mineral-fiber insulation inside frames.
  4. Masonry Walls: Coordinate installation of frames to allow for solidly filling space between frames and masonry with grout.
  5. Concrete Walls: Solidly fill space between frames and concrete with mineral-fiber insulation.
  6. In-Place Concrete or Masonry Construction: Secure frames in place with post-installed expansion anchors. Countersink anchors, and fill and make smooth, flush, and invisible on exposed faces.
  7. In-Place Metal or Wood-Stud Partitions: Secure slip-on drywall frames in place according to manufacturer's written instructions.
  8. Installation Tolerances: Adjust hollow-metal door frames for squareness, alignment, twist, and plumb to the following tolerances:
    - a. Squareness: Plus or minus 1/16 inch, measured at door rabbet on a line 90 degrees from jamb perpendicular to frame head.
    - b. Alignment: Plus or minus 1/16 inch, measured at jambs on a horizontal line parallel to plane of wall.
    - c. Twist: Plus or minus 1/16 inch, measured at opposite face corners of jambs on parallel lines, and perpendicular to plane of wall.
    - d. Plumbness: Plus or minus 1/16 inch, measured at jambs at floor.
- C. Hollow-Metal Doors: Fit hollow-metal doors accurately in frames, within clearances specified below. Shim as necessary.
1. Non-Fire-Rated Steel Doors:
    - a. Between Door and Frame Jambs and Head: 1/8 inch plus or minus 1/32 inch.
    - b. Between Edges of Pairs of Doors: 1/8 inch to 1/4 inch plus or minus 1/32

- inch.
    - c. At Bottom of Door: 3/4 inch plus or minus 1/32 inch.
    - d. Between Door Face and Stop: 1/16 inch to 1/8 inch plus or minus 1/32 inch.
  - 2. Fire-Rated Doors: Install doors with clearances according to NFPA 80.
  - 3. Smoke-Control Doors: Install doors and gaskets according to NFPA 105.
- D. Glazing: Comply with installation requirements in Section 08 80 00 "Glazing" and with hollow metal manufacturer's written instructions.
  - 1. Secure stops with countersunk flat- or oval-head machine screws spaced uniformly not more than 9 inches o.c. and not more than 2 inches o.c. from each corner.

### 3.4 ADJUSTING AND CLEANING

- A. Final Adjustments: Check and readjust operating hardware items immediately before final inspection. Leave work in complete and proper operating condition. Remove and replace defective work, including hollow-metal work that is warped, bowed, or otherwise unacceptable.
- B. Remove grout and other bonding material from hollow-metal work immediately after installation.
- C. Prime-Coat Touch-up: Immediately after erection, sand smooth rusted or damaged areas of prime coat and apply touch-up of compatible air-drying, rust-inhibitive primer.
- D. Metallic-Coated Surface Touch-up: Clean abraded areas and repair with galvanizing repair paint according to manufacturer's written instructions.
- E. Factory-Finish Touch-up: Clean abraded areas and repair with same material used for factory finish according to manufacturer's written instructions.
- F. Touch-up Painting: Cleaning and touch-up painting of abraded areas of paint are specified in painting Sections.

- END OF SECTION -

## SECTION 08 56 53 – SECURITY WINDOWS

### PART 1 - GENERAL

#### 1.1 SECTION INCLUDES

- A. Interior Bullet Resisting Barriers with Vertical Baffles

#### 1.2 ACTION SUBMITTALS

- A. Refer to Section 01 33 00 Submittal Procedures.
- B. Product Data: For each type of window provide Level 3 protection.
- C. Shop Drawings: Include plans, elevations, sections, details, anchorage to other work.

#### 1.3 INFORMATION SUBMITTALS

- A. Product Test Reports: Indicating compliance with requirements

#### 1.4 CLOSEOUT SUBMITTALS

- A. Refer to Section 01 78 00 Closeout Submittals.
- B. Cleaning Instructions

#### 1.5 DELIVERY, STORAGE AND HANDLING

- A. Refer to Section 01 60 00 Product Requirements

#### 1.6 WARRANTY

- A. Special Warranty for Security Glass - Acrylic
  - 1. Manufacturer agrees to replace glass units that deteriorate within a period of 20 years. Deterioration includes the development of defects that are not caused by breakage, or improper maintenance and cleaning. Defects as identified by the glass manufacturer include:
    - a. Discoloration of coating in excess of 3% when tested in accordance with ASTM D 1003 - Standard Test Method for Haze and Luminous Transmittance of Transparent Plastics.
    - b. Chipping of abrasions resistant coating
- B. Special Warranty for Security Glass - Laminate (Lexgard)

1. Manufacturer agrees to replace glass units that deteriorate within a period of 10 years. Deterioration includes the development of defects that are not caused by breakage, or improper maintenance and cleaning. Defects as identified by the glass manufacturer the include:
  - a. Structural Delamination
  - b. Coating Failure
  - c. Haze of more than 15%

## PART 2 - PRODUCTS

### 2.1 MANUFACTURED UNIT

- A. Preferred Manufacturer: Total Security Solutions
- B. Acceptable Manufacturer: Insulgard
- C. Acceptable Manufacturer: Defenselite
- D. Substitutions: Permitted per General Conditions
  1. Subject to compliance with requirements, manufacturers of products of equivalent design may be acceptable if approved in accordance with Section 01 25 00 Substitution Procedures.

### 2.2 DESCRIPTION

- A. Glazing for panels and support buttresses:
  1. Level 3: 1-1/4 inch SP1250 Lexgard
- B. Fasteners and Fittings
  1. Clips, fasteners and anchors: Manufacturer standards stainless steel, chrome
  2. Bottom Glass Rail: Anodized Aluminum "U" Channel to accommodate thickness of glass.
- C. Accessories
  1. Surface Mounted Deal Tray: stainless steel
  2. PE Package Passer:
    - a. Constructed of glazing materials consistent with UL Level for the Barrier Assembly
    - b. Size custom sizes per plans

### 2.3 PERFORMANCE CRITERIA

- A. Ballistic Resistant: Level **3** in accordance with UL 752 – Testing for Ballistic Resistance for the framing and glazing.

## 2.4 FABRICATION

- A. Fabricate from manufacturer's standard materials to comply with indicated ballistic resistance requirements

## PART 3 - EXECUTION

### 3.1 PREPARATION

- A. Verify field dimensions of opening prior to fabrication of counterline window.
- B. Coordinate structural requirements to ensure proper attachment and support.

### 3.2 INSTALLATION

- A. Install counterline windows in accordance with manufacturer's recommendations and approved shop drawings.
- B. Provide required support and securely fasten and set windows plumb, square, and level without twist or bow.

### 3.3 CLEANING

- A. Clean security window surfaces after installation, avoiding damage to finishes. Remove excess glazing and sealant compound and dirt.

### 3.4 PROTECTION

- A. Protect transaction windows damage during construction operations. If damage occurs, remove and replace as required to provide windows in their original, undamaged condition.

END OF SECTION

## GYPSUM BOARD – SECTION 09 25 00

### PART ONE GENERAL

#### 1.1 SECTION INCLUDES

- A. Gypsum board wall panels.
- B. Accessories and Trim.

#### 1.2 RELATED SECTIONS

- A. Section 09 91 00 – Painting.

#### 1.3 REFERENCES

- A. ASTM C473 - Standard Test Methods for Physical Testing of Gypsum Panel Products.
- B. ASTM C 475 - Standard Specification for Joint Compound and Joint Tape for Finishing Gypsum Board.
- C. ASTM C 514 - Standard Specifications for Nails for the Application of Gypsum Board.
- D. ASTM C 840 - Standard Specification for Application and Finishing of Gypsum Board.
- E. ASTM C 1002 - Standard Specification for Steel Self-Piercing Tapping Screws for the Application of Gypsum Panel Products or Metal Plaster Bases to Wood Studs or Steel Studs.
- F. ASTM C 1047 - Standard Specification for Accessories For Gypsum Wallboard and Gypsum Veneer Base.
- G. ASTM C 1396 - Standard Specification for Gypsum Board.
- H. ASTM D 3273 - Standard Test Method for Resistance to Growth of Mold on the Surface of Interior Coatings in an Environmental Chamber.
- I. GA-214 - Recommended Levels of Gypsum Board Finish.
- J. GA-216 - Application and Finishing of Gypsum Board.
- K. GA-231 - Assessing Water damage to Gypsum Board.
- L. GA-238 - Guidelines for the Prevention of Mold Growth on Gypsum Board.

#### 1.4 SUBMITTALS

- A. Submit under provisions of Section 01 33 00.
- B. Product Data: Manufacturer's data sheets on each product to be used, including:
  - 1. Preparation instructions and recommendations.
  - 2. Storage and handling requirements and recommendations.
  - 3. Design data test reports.
  - 4. Installation methods.

- C. Manufacturer's Certificates: Certify products meet or exceed specified requirements.

## 1.5 QUALITY ASSURANCE

- A. Manufacturer Qualifications: Company specializing in manufacturing products specified in this section with minimum ten years documented experience.
- B. Installer Qualifications: Company specializing in performing Work of this section with minimum three years documented experience.

## 1.6 DELIVERY, STORAGE, AND HANDLING

- A. Store products in manufacturer's unopened packaging indicating manufacturer and product name and protect until ready for installation.
- B. Store gypsum in accordance with GA-238 and manufacturer recommendations.

## 1.7 PROJECT CONDITIONS

- A. Maintain environmental conditions (temperature, humidity, and ventilation) in accordance with ASTM C 840 and within limits recommended by manufacturer for optimum results. Do not install products under environmental conditions outside manufacturer's absolute limits.

# PART TWO PRODUCTS

## 2.1 GYPSUM BOARD WALL PANELS

- A. Standard Gypsum Board Products:
  - 1. Regular Gypsum Board: Gypsum core panel solid set core enclosed in paper. Complying with ASTM C1396.
- B. Moisture and Mold Resistant Products:
  - 1. Moisture and Mold Resistant Gypsum Board: Gypsum core panel with enhanced core formulated for resistance to moisture and mold; surfaced with moisture/mold resistant paper on front, back, and long edges. Complying with ASTM C 1396.
  - 2. Fire Rated Moisture and Mold Resistant Gypsum Board: Gypsum core panel with enhanced core formulated for resistance to moisture and mold; for use in fire-resistant Type X designs. Surfaced with moisture/ mold resistant paper of front, back, and long edges. Complying with ASTM C 1396.
- C. High Performance Products:
  - 1. Abuse Resistant Gypsum Board: Gypsum core panel with enhanced core to provide resistance to abuse. Complying with ASTM C 1396.
  - 2. Fire Rated Abuse Resistant Gypsum Board: Gypsum core panel with enhanced core to provide resistance to abuse for use in fire-resistive Type X designs. Complying with ASTM C 1396, Type X.
  - 3. Fire Rated Shaft Liner Gypsum Board: Gypsum core shaftwall panel with enhanced fire resistant core. Complying with ASTM C 1396 Type X.

## 2.2 GYPSUM BOARD CEILING AND SOFFIT PANELS

- A. Interior Ceiling Board.
  - 1. Regular Gypsum Ceiling Board: Gypsum Core panel with enhanced sag resistant core. Complying with ASTM C 1396.

## 2.3 ACCESSORIES

- A. Interior Trim: Complying with ASTM C 1047.
  - 1. Corner Bead
  - 2. Control Joint
- B. Fasteners:
  - 1. Screws: ASTM C 954 or ASTM C 1002 as recommended by panel manufacturer.
  - 2. Adhesive: Recommended by panel manufacturer.
- C. Joint Treatment:
  - 1. Tape: Comply with ASTM C 475.
  - 2. Joint Compound: Comply with ASTM C 475.
- D. Sealants and Caulking: Provide Joint Sealant and Acoustical Sealant as specified in Section 07 92 00.
- E. Insulation: Thermal and acoustical insulation as specified in Section 07 21 00.

## PART THREE EXECUTION

### 3.1 EXAMINATION

- A. Do not begin installation until supports and substrates have been properly prepared.
- B. Verify that framing and supports are ready to receive work and opening dimensions are as indicated on the Drawings.
- C. If support and substrate preparation is the responsibility of another installer, notify Architect of unsatisfactory preparation before proceeding.

### 3.2 PREPARATION

- A. Clean surfaces thoroughly prior to installation.
- B. Examine gypsum board panels for damage and existence of mold. Install undamaged panels.
- C. Examine gypsum board in accordance with GA 231 for water damage.
- D. Prepare surfaces using the methods recommended by the manufacturer for achieving the best result for the substrate under the project conditions.

### 3.3 INSTALLATION

- A. Install in accordance with manufacturer's written instructions and ASTM C 840 and GA 216.
- B. Erect single layer gypsum board in most economical direction with ends and edges occurring over firm bearing.
- C. Erect single layer fire rated gypsum board with edges and ends occurring over firm bearing.

- D. Place control joints consistent with lines of building spaces as indicated on Drawings.
- E. Place corner beads at external corners. Use longest practical length. Place edge trim where gypsum board abuts dissimilar materials.

#### 3.4 FINISHING

- A. General: Comply with ASTM C 840, GA 214 and GA 216.
  - 1. Level 1: All areas to receive flat sheen paint finish.

#### 3.5 PROTECTION

- A. Protect installed products until completion of project.
- B. Touch-up, repair or replace damaged products before Substantial Completion.

- END OF SECTION -

## ACOUSTICAL PANEL CEILINGS – SECTION 09 51 13

### PART ONE GENERAL

#### 1.1 RELATED DOCUMENTS

- A. Drawings and general conditions of Contract.

#### 1.2 SUMMARY

A. Section Includes:

1. Acoustical ceiling panels.
2. Exposed grid suspension system.
3. Wire hangers, fasteners, main runners, cross tees, and wall angle moldings.

B. Alternates

1. Prior Approval: Unless otherwise provided for in the Contract documents, proposed product substitutions may be submitted no later than TEN (10) working days prior to the date established for receipt of bids. Acceptability of a proposed substitution is contingent upon the Architect's review of the proposal for acceptability and approved products will be set forth by the Addenda. If included in a Bid are substitute products which have not been approved by Addenda, the specified products shall be provided without additional compensation.
2. Submittals which do not provide adequate data for the product evaluation will not be considered. The proposed substitution must meet all requirements of this section, including but not necessarily limited to, the following: Single source materials suppliers (if specified in Section 1.5); Underwriters' Laboratories Classified Acoustical performance; Panel design, size, composition, color, and finish; Suspension system component profiles and sizes; Compliance with the referenced standards.

#### 1.3 REFERENCES

A. American Society for Testing and Materials (ASTM):

1. ASTM C 635 Standard Specification for Metal Suspension Systems for Acoustical Tile and Lay-in Panel Ceilings.
2. ASTM C 636 Recommended Practice for Installation of Metal Ceiling Suspension Systems for Acoustical Tile and Lay-in Panels.
3. ASTM E 84 Standard Test Method for Surface Burning Characteristics of Building Materials.
4. ASTM E 1414 Standard Test Method for Airborne Sound Attenuation Between Rooms Sharing a Common Ceiling Plenum.
5. ASTM E 1111 Standard Test Method for Measuring the Interzone Attenuation of Ceilings Systems.
6. ASTM E 1264 Classification for Acoustical Ceiling Products.
7. ASTM E 1477 Standard Test Method for Luminous Reflectance Factor of Acoustical Materials by Use of Integrating-Sphere Reflectometers.
8. ASTM D 3273 Standard Test Method for Resistance to Growth of Mold on the Surface of Interior Coatings in an Environmental Chamber.
9. ASTM E 119 Standard Test Methods for Fire Tests of Building Construction and Material.

B. ASHRAE Standard 62.1-2004, "Ventilation for Acceptable Indoor Air Quality"

#### 1.4 SUBMITTALS

- A. Product Data: Submit manufacturer's technical data for each type of acoustical ceiling unit and suspension system required.
- B. Samples: Minimum 6 inch x 6 inch samples of specified acoustical panel; 8 inch long samples of exposed wall molding and suspension system, including main runner and 4 foot cross tees.
- C. Shop Drawings: Layout and details of acoustical ceilings. Show locations of items which are to be coordinated with or supported by the ceilings.
- D. Certifications: Manufacturer's certifications that products comply with specified requirements, including laboratory reports showing compliance with specified tests and standards. For acoustical performance, each carton of material must carry an approved independent laboratory classification of NRC, CAC, and AC.
- E. If the material supplied by the acoustical subcontractor does not have an Underwriter's Laboratory classification of acoustical performance on every carton, subcontractor shall be required to send material from every production run appearing on the job to an independent or NVLAP approved laboratory for testing, at the architect's or owner's discretion. All products not conforming to manufacturer's current published values must be removed, disposed of and replaced with complying product at the expense of the Contractor performing the work.

#### 1.5 QUALITY ASSURANCE

- A. Single-Source Responsibility: To match the existing system, provide acoustical panel units and grid components by a single manufacturer.
- B. Fire Performance Characteristics: Identify acoustical ceiling components with appropriate markings of applicable testing and inspecting organization.
  - 1. Surface Burning Characteristics: As follows, tested per ASTM E 84 and complying with ASTM E 1264 for Class A products.
    - a. Flame Spread: 25 or less
    - b. Smoke Developed: 50 or less
- C. Handle acoustical ceiling units carefully to avoid chipping edges or damaged units in any way.

#### 1.6 DELIVERY, STORAGE, AND HANDLING

- A. Deliver acoustical ceiling units to project site in original, unopened packages and store them in a fully enclosed space where they will be protected against damage from moisture, direct sunlight, surface contamination, and other causes.
- B. Before installing acoustical ceiling units, permit them to reach room temperature and a stabilized moisture content.
- C. Handle acoustical ceiling units carefully to avoid chipping edges or damaged units in any way.

#### 1.7 PROJECT CONDITIONS

- A. Space Enclosure: All ceiling products and suspension systems must be installed and maintained in accordance with Armstrong written installation instructions for that product in effect at the time of installation and best industry practice. Prior to installation, the ceiling product must be kept clean and dry, in an environment that is between 32°F (0°C)

and 120°F (49°C) and not subject to Abnormal Conditions. Abnormal conditions include exposure to chemical fumes, vibrations, moisture from conditions such as building leaks or condensation, excessive humidity, or excessive dirt or dust buildup. HumiGuard Plus Ceilings: Installation of the products shall be carried out where the temperature is between 32°F (0° C) and 120°F (49° C). It is not necessary for the area to be enclosed or for HVAC systems to be functioning. All wet work (plastering, concrete, etc) must be complete and dry. The ceilings must be maintained to avoid excessive dirt or dust buildup that would provide a medium for microbial growth on ceiling panels. Microbial protection does not extend beyond the treated surface as received from the factory and does not protect other materials that contact the treated surface such as supported insulation materials.

## 1.8 WARRANTY

- A. Acoustical Panel: Submit a written warranty executed by the manufacturer, agreeing to repair or replace acoustical panels that fail within the warranty period. Failures include, but are not limited to:
  - 1. Acoustical Panels: Sagging and warping as a result of defects in materials or factory workmanship.
  - 2. Grid System: Rusting and manufacturer's defects
  - 3. Acoustical Panels with BioBlock Plus or designated as inherently resistive to the growth of micro-organisms installed with Armstrong suspension systems: Visible sag and will resist the growth of mold/mildew and gram positive and gram negative odor and stain causing bacteria.
- B. Warranty Period Humiguard:
  - 1. Acoustical panels: Ten (10) years from date of substantial completion.
  - 2. Grid: Ten (10) years from date of substantial completion.
  - 3. Acoustical panels and grid systems with HumiGuard Plus or HumiGuard Max performance supplied by one source manufacturer is thirty (30) years from date of substantial completion.
- C. The Warranty shall not deprive the Owner of other rights the Owner may have under other provisions of the Contract Documents and will be in addition to and run concurrent with other warranties made by the Contractor under the requirements of the Contract Documents.

## 1.9 MAINTENANCE

- A. Extra Materials: Deliver extra materials to Owner. Furnish extra materials described below that match products installed. Packaged with protective covering for storage and identified with appropriate labels.
  - 1. Acoustical Ceiling Units: Furnish quality of full-size units equal to 5.0 percent of amount installed.
  - 2. Exposed Suspension System Components: Furnish quantity of each exposed suspension component equal to 2.0 percent of amount installed.

## PART TWO PRODUCTS

### 2.1 MANUFACTURERS

- A. Ceiling Panels:
  - 1. Match existing panels

### 2.2 ACOUSTICAL CEILING UNITS

- A. Acoustical Panels Type ACT-1:
1. Surface Texture: Fine
  2. Composition: Mineral Fiber
  3. Color: White
  4. Size: 24in X 24in X 3/4in
  5. Edge Profile: Flat non-regular for interface with compatible Armstrong grid.
  6. Noise Reduction Coefficient (NRC): ASTM C 423; Classified with UL label on product carton, 0.65.
  7. Ceiling Attenuation Class (CAC): ASTM C 1414; Classified with UL label on product carton, 35
  8. Emissions Testing: Section 01350 Protocol, < 13.5 ppb of formaldehyde when used under typical conditions required by ASHRAE Standard 62.1-2004, "Ventilation for Acceptable Indoor Air Quality"
  9. Flame Spread: ASTM E 1264; Class A (UL)
  10. Light Reflectance (LR): ASTM E 1477; White Panel: Light Reflectance: 0.86.
  11. Dimensional Stability: HumiGuard Plus - Temperature is between 32°F (0° C) and 120°F (49° C). It is not necessary for the area to be enclosed or for HVAC systems to be functioning. All wet work (plastering, concrete, etc) must be complete and dry.
  12. Antimicrobial Protection: BioBlock Plus - Resistance against the growth of mold/mildew and gram positive and gram negative odor and stain causing bacteria.
- B. Acoustical Panels Type ACT-2:
1. Surface Texture: Fine
  2. Composition: Mineral Fiber
  3. Color: White
  4. Size: 24in X 24in X 3/4in
  5. Edge Profile: Flat non-regular for interface with compatible Armstrong grid.
  6. Noise Reduction Coefficient (NRC): ASTM C 423; Classified with UL label on product carton, 0.65.
  7. Ceiling Attenuation Class (CAC): ASTM C 1414; Classified with UL label on product carton, 35
  8. Emissions Testing: Section 01350 Protocol, < 13.5 ppb of formaldehyde when used under typical conditions required by ASHRAE Standard 62.1-2004, "Ventilation for Acceptable Indoor Air Quality"
  9. Flame Spread: ASTM E 1264; Class A (UL)
  10. Light Reflectance (LR): ASTM E 1477; White Panel: Light Reflectance: 0.86.
  11. Dimensional Stability: HumiGuard Plus - Temperature is between 32°F (0° C) and 120°F (49° C). It is not necessary for the area to be enclosed or for HVAC systems to be functioning. All wet work (plastering, concrete, etc) must be complete and dry.
  12. Antimicrobial Protection: BioBlock Plus - Resistance against the growth of mold/mildew and gram positive and gram negative odor and stain causing bacteria.

## PART THREE EXECUTION

### 3.1 EXAMINATION

- A. Do not proceed with installation until all wet work such as concrete, terrazzo, plastering and painting has been completed and thoroughly dried out, unless expressly permitted by manufacturer's printed recommendations. (Exception: HumiGuard Max Ceilings)

### 3.2 PREPARATION

- A. Measure each ceiling area and establish layout of acoustical units to balance border widths at opposite edges of each ceiling. Avoid use of less than half width units at borders and comply with reflected ceiling plans. Coordinate panel layout with mechanical and electrical fixtures.
- B. Coordination: Furnish layouts for preset inserts, clips, and other ceiling anchors whose installation is specified in other sections.
  - 1. Furnish concrete inserts and similar devices to other trades for installation well in advance of time needed for coordination of other work.

### 3.3 INSTALLATION

- A. Install suspension system and panels in accordance with the manufacturer's instructions, and in compliance with ASTM C 636 and with the authorities having jurisdiction.
- B. Suspend main beam from overhead construction with hanger wires spaced 4-0 on center along the length of the main runner. Install hanger wires plumb and straight.
- C. Install wall moldings at intersection of suspended ceiling and vertical surfaces. Miter corners where wall moldings intersect or install corner caps.
- D. For reveal edge panels: Cut and reveal or rabbet edges of ceiling panels at border areas and vertical surfaces.
- E. Install acoustical panels in coordination with suspended system, with edges resting on flanges of main runner and cross tees. Cut and fit panels neatly against abutting surfaces. Support edges by wall moldings.

### 3.4 ADJUSTING AND CLEANING

- A. Replace damaged and broken panels.
- B. Clean exposed surfaces of acoustical ceilings, including trim, edge moldings, and suspension members. Comply with manufacturer's instructions for cleaning and touch up of minor finish damage.
  - 1. Ceiling Touch-Up Paint, (Item #5760, 8oz. bottles) (Item #5761, quart size cans), "global white" latex paint should be used to hide minor scratches and nicks in the surface and to cover field tegularized edges that are exposed to view.
- C. Remove and replace work that cannot be successfully cleaned and repaired to permanently eliminate evidence of damage.

- END OF SECTION -

## PAINTING – SECTION 09 91 00

### PART ONE GENERAL

#### 1.1 SECTION INCLUDES

- A. Surface preparation and field painting of exposed interior items and surfaces, including mechanical and electrical equipment that do not have a factory-applied finish.

#### 1.2 RELATED SECTIONS

- A. Section 08 11 13 – Hollow Metal Doors and Frames
- B. Section 09 25 00 - Gypsum Board

#### 1.3 REFERENCES

- A. American Society for Testing and Materials (ASTM) D 16 - Standard Terminology for Paint, Related Coatings, Materials, and Applications.

#### 1.4 SUBMITTALS

- A. Submit under provisions of Section 01 33 00.
- B. Product Data: Manufacturer's data sheets on each product to be used, including:
  - 1. Material List: An inclusive list of required coating materials. Indicate each material and cross-reference specific coating, finish system, and application. Identify each material by manufacturer's catalog number and general classification.
  - 2. Preparation instructions and recommendations.
  - 3. Manufacturer's Information: Manufacturer's technical information, including label analysis and instructions for handling, storing, and applying each coating material.
- C. Selection Samples: For each finish product specified, two complete sets of color chips representing manufacturer's full range of available colors and patterns.
- D. Verification Samples: For each finish product specified, two samples, minimum size 6 inches (150 mm) square, representing actual product, color, and patterns.

#### 1.5 QUALITY ASSURANCE

- A. Installer Qualifications: A firm or individual experienced in applying paints and coatings similar in material, design, and extent to those indicated for this Project, whose work has resulted in applications with a record of successful in-service performance.
- B. Obtain block fillers and primers for each coating system from the same manufacturer as the finish coats.
- C. Paint exposed surfaces. If an item or a surface is not specifically mentioned, paint the item or surface the same as similar adjacent materials or surfaces. If a color of finish is not indicated, Owner will select from standard colors and finishes available.
- D. Do not paint prefinished items, concealed surfaces, finished metal surfaces, operating parts, and labels.

- E. Mock-Up: Provide a mock-up for evaluation of surface preparation techniques and application workmanship.
  - 1. Finish areas designated by Architect.
  - 2. Do not proceed with remaining work until workmanship, color, and sheen are approved by Architect or Owner.
  - 3. Refinish mock-up area as required to produce acceptable work.

#### 1.6 DELIVERY, STORAGE, AND HANDLING

- A. Deliver materials to Project site in manufacturer's original, unopened packages and containers bearing manufacturer's name and label.
- B. Store materials not in use in tightly covered containers in a well-ventilated area at a minimum ambient temperature of 45°F (7°C). Maintain storage containers in a clean condition, free of foreign materials and residue.
- C. Maintain environmental conditions (temperature, humidity, and ventilation) within limits recommended by manufacturer for optimum results. Do not install products under environmental conditions outside manufacturer's absolute limits.
- D. Apply waterborne paints only when temperatures of surfaces to be painted and surrounding air are between 50 and 90°F (10 and 32°C), unless manufacturer's instructions specifically states.
- E. Apply solvent-thinned paints only when temperatures of surfaces to be painted and surrounding air are between 45 and 95°F (7 and 35°C).
- F. Store and dispose of solvent-based materials, and materials used with solvent-based materials, in accordance with requirements of local authorities having jurisdiction.

#### 1.7 PROJECT CONDITIONS

- A. Maintain environmental conditions (temperature, humidity, and ventilation) within limits recommended by manufacturer for optimum results. Do not install products under environmental conditions outside manufacturer's absolute limits.

#### 1.8 EXTRA MATERIALS

- A. Furnish extra paint materials from the same production run as the materials applied and, in the quantities, described below. Package with protective covering for storage and identify with labels describing contents. Deliver extra materials to Owner.
- B. Quantity: Furnish Owner with an additional three percent, but not less than 1 gal (3.8 l) or 1 case, as appropriate, of each material and color applied.

### PART TWO PRODUCTS

#### 2.1 MANUFACTURERS

- A. Acceptable Manufacturer: BEHR.
- B. Acceptable Manufacturer: Sherwin Williams.
- C. Acceptable Manufacturer: Benjamin Moore.

- D. Substitutions: Permitted.
- E. Requests for substitutions will be considered in accordance with provisions of Section 01 60 00.

## 2.2 PAINT MATERIALS - GENERAL

- A. Material Compatibility: Provide block fillers, primers, and finish-coat materials that are compatible with one another and with the substrates indicated under conditions of service and application, as demonstrated by manufacturer based on testing and field experience.
- B. VOC Classification: Provide materials, including primers, undercoats, and finish-coat materials, that meet local air quality management district regulations.
- C. Color: Refer to Finish Schedule and Paint Legend for paint colors.
- D. Application Rate: Coating thickness for primer, intermediate, barrier and finish coats shall be measured as Dry Film Thickness (DFT) and comply with manufacturer's published recommendations.

## 2.3 INTERIOR PAINT SYSTEMS

- A. Drywall / Gypsum Wallboard: MPI Gloss Level 1 - Flat, <5 at 60°:
  - 1. One Prime Coat: (If primer is required per product instruction)
    - a. Latex Interior/Exterior Water-Based Primer.
  - 2. Two finish coats:
    - a. Interior Flat Enamel Paint.
    - b. Interior Flat Paint.
    - c. Interior Ceiling Paint
    - d. Interior Dead Flat Paint.
    - e. Interior Flat Paint.
- B. Drywall / Gypsum Wallboard: MPI Gloss Level 2 - Low Sheen, <10 at 60°:
  - 1. One Prime Coat: (If primer is required per product instruction)
    - a. Latex Interior/Exterior Water-Based Primer.
  - 2. Two finish coats:
    - a. Interior Flat Enamel Paint.
    - b. Interior Eggshell Paint.
- C. Drywall / Gypsum Wallboard: MPI Gloss Level 3 - Eggshell, 10-25 at 60°:
  - 1. One Prime Coat: (If primer is required per product instruction)
    - a. Latex Interior/Exterior Water-Based Primer.
  - 2. Two finish coats:
    - a. Interior Eggshell Enamel Paint.
    - b. Interior Eggshell Paint.
- D. Drywall / Gypsum Wallboard: MPI Gloss Level 4 - Satin, 25-35 at 60°:
  - 1. One Prime Coat: (If primer is required per product instruction)
    - a. Latex Interior/Exterior Water-Based Primer.
  - 2. Two finish coats:
    - a. Interior Satin Enamel Paint.
- E. Drywall / Gypsum Wallboard: MPI Gloss Level 5 - Semi-Gloss, 35-70 at 60°:
  - 1. One Prime Coat: (If primer is required per product instruction)
    - a. Latex Interior/Exterior Water-Based Primer.

- 2. Two finish coats:
  - a. Interior Semi-Gloss Enamel Paint.
  - b. Interior Semi-Gloss Paint.
  
- F. Drywall / Gypsum Wallboard: MPI Gloss Level 6 - Gloss, 70-85 at 60°:
  - 1. One Prime Coat: (If primer is required per product instruction)
    - a. Latex Interior/Exterior Water-Based Primer.
  - 2. Two finish coats:
    - a. Interior/Exterior Hi-Gloss Enamel Paint.
  
- G. Drywall / Gypsum Wallboard Gloss Level 7 - Gloss, 85+ at 60°:
  - 1. One Prime Coat: (If primer is required per product instruction)
    - a. Latex Interior/Exterior Water-Based Primer.
  - 2. Two finish coats:
    - a. Interior/Exterior HIGH GLOSS ENAMEL Paint.
  
- H. Wood - Millwork, Paint Grade:
  - 1. One Prime Coat: (If primer is required per product instruction)
    - a. Latex Interior/Exterior Water-Based Primer.
  - 2. Two finish coats:
    - a. Interior Paint.
    - d. Interior/Exterior SEMI-GLOSS ENAMEL.
    - e. Interior/Exterior HIGH GLOSS ENAMEL.

## PART THREE EXECUTION

### 3.1 EXAMINATION

- A. Do not begin installation until substrates have been properly prepared.
- B. If substrate preparation is the responsibility of another installer, notify Owner of unsatisfactory preparation before proceeding.
- C. Coordination of Work: Review other Sections in which primers are provided to ensure compatibility of the total system for various substrates. On request, furnish information on characteristics of finish materials to ensure use of compatible primers.
  - 1. Notify Owner about anticipated problems when using the materials specified over substrates primed by others.
  - 2. If a potential incompatibility of primers applied by others exists, obtain the following from the primer Applicator before proceeding:
    - a. Confirmation of primer's suitability for expected service conditions.
    - b. Confirmation of primer's ability to be top coated with materials specified.

### 3.2 PREPARATION

- A. General: Remove hardware and hardware accessories, plates, machined surfaces, lighting fixtures, and similar items already installed that are not to be painted. If removal is impractical or impossible because of size or weight of the item, provide surface-applied protection before surface preparation and painting.
  - 1. After completing painting operations in each space or area, reinstall items removed using workers skilled in the trades involved.

- B. Cleaning: Before applying paint or other surface treatments, clean substrates of substances that could impair bond of the various coatings. Remove oil and grease before cleaning.
  - 1. Schedule cleaning and painting so dust and other contaminants from the cleaning process will not fall on wet, newly painted surfaces.
  
- C. Surface Preparation: Clean and prepare surfaces to be painted according to manufacturer's written instructions for each particular substrate condition and as specified.
  - 1. Provide barrier coats over incompatible primers or remove and re-prime.
  - 2. Provide barrier coats over incompatible primers or remove primers and re-prime substrate.
  - 3. Cementitious Substrates: Prepare concrete, brick, concrete masonry block, and cement plaster surfaces to be coated. Remove efflorescence, chalk, dust, dirt, grease, oils, and release agents. Roughen as required to remove glaze. If hardeners or sealers have been used to improve curing, use mechanical methods to prepare surfaces.
    - a. Use abrasive blast-cleaning methods if recommended by coating manufacturer.
    - b. Determine alkalinity and moisture content of surfaces by performing appropriate tests. If surfaces are sufficiently alkaline to cause the finish paint to blister and burn, correct this condition before application. Do not coat surfaces if moisture content exceeds that permitted in manufacturer's written instructions.
  - 4. Wood Substrates: Clean surfaces of dirt, oil, and other foreign substances with scrapers, mineral spirits, and sandpaper, as required. Smoothly sand surfaces exposed to view and dust off.
    - a. Scrape and clean small, dry, seasoned knots, and apply a thin coat of white shellac or other recommended knot sealer, before applying primer.
    - b. Immediately on delivery, prime edges, ends, faces, undersides, and backsides of wood to be coated.
    - c. After priming, fill holes and imperfections in the finish surfaces with putty or plastic wood filler. Sand smooth when dried.
    - d. Determine moisture content of surfaces by performing a moisture test. Do not coat if moisture content exceeds 15 percent.
  
- D. Material Preparation: Carefully mix and prepare coating materials according to manufacturer's written instructions.
  - 1. Maintain containers used in mixing and applying coatings in a clean condition, free of foreign materials and residue.
  - 2. Stir materials before applying to produce a mixture of uniform density. Stir as required during application. Do not stir surface film into the material. Remove film and, if necessary, strain coating material before using.
  - 3. Use only the type of thinners approved by manufacturer and only within recommended limits.
  - 4. Tinting: Tint each undercoat a lighter shade to simplify identification of each coat when multiple coats of same material are applied. Tint undercoats to match the color of the finish coat but provide sufficient differences in shade of undercoats to distinguish each separate coat.

### 3.3 APPLICATION

- A. General: Apply paint according to manufacturer's written instructions. Use applicators and techniques best suited for substrate and type of material being applied.

- B. General: Apply high-performance coatings according to manufacturer's written instructions.
  1. Use applicators and techniques best suited for the material being applied.
  2. Do not apply high-performance coatings over dirt, rust, scale, grease, moisture, scuffed surfaces, or conditions detrimental to forming a durable coating film.
  3. Coating surface treatments, and finishes are indicated in the coating system descriptions.
  4. Provide finish coats compatible with primers used.
  5. The term "exposed surfaces" includes areas visible when permanent or built-in fixtures, convector covers, grilles, covers for finned-tube radiation, and similar components are in place. Extend coatings in these areas, as required, to maintain system integrity and provide desired protection.
  
- C. Application Procedures: Apply coatings by brush, roller, spray, or other applicators according to manufacturer's written instructions.
  1. The number of coats and film thickness required is the same regardless of application method.
  2. Completed Work: Match approved Samples for color, texture, and coverage. Remove, refinish, or recoat work that does not comply with specified requirements.

### 3.4 FIELD QUALITY CONTROL

- A. Owner reserves the right to invoke the following test procedure at any time and as often as Owner deems necessary during the period when paint is being applied:
  1. Owner will engage a qualified independent testing agency to sample paint material being used. Samples of material delivered to Project will be taken, identified, sealed, and certified in the presence of Contractor.
  2. Owner may direct Contractor to stop painting if test results show material being used does not comply with specified requirements. Contractor shall remove non-complying paint from Project site, pay for testing, and repaint surfaces previously coated with the non-complying paint. If necessary, Contractor may be required to remove non-complying paint from previously painted surfaces if, on repainting with specified paint, the two coatings are incompatible.

### 3.5 CLEANING

- A. After completing painting, clean glass and paint-spattered surfaces. Remove spattered paint by washing and scraping without scratching or damaging adjacent finished surfaces.

### 3.6 PROTECTION

- A. Protect work of other trades, whether being painted or not, against damage from painting. Correct damage by cleaning, repairing or replacing, and repainting, as approved by Architect.
- B. Provide "Wet Paint" signs to protect newly painted finishes. After completing painting operations, remove temporary protective wrappings provided by others to protect their work.
- C. After work of other trades is complete, touch up and restore damaged or defaced painted surfaces.

- END OF SECTION -

## BULLET RESISTANT PANELS - SECTION 10 26 41

### PART 1 – GENERAL

#### 1.1 SUMMARY

- A. Section includes bullet resistant fiberglass panels.

#### 1.2 REFERENCES

- A. American Society for Testing and Materials:
  - 1. ASTM E119-98 Standard Test for One-Hour Fire-Rating of Building Construction and Materials
  - 2. ASTM F1233-98 Standard Test Method for Forced Entry Testing of Materials/Assemblies, Class IV
- B. International Organization for Standardization:
  - 1. ISO 9001:2015 Quality Management System
- C. National Institute of Justice Ballistic Standards:
  - 1. NIJ Standard 0108.01 – Type III-A
- D. Underwriters Laboratories:
  - 1. UL 752 Specifications and Ammunition, 11th Edition, Standard for Bullet Resisting Equipment published September 9, 2005, revised December 21, 2006, Level 3
- E. The United States Department of State:
  - 1. The International Traffic in Arms Regulations (ITAR)

#### 1.3 SUBMITTALS

- A. Submittals for Review: Submit for approval prior to fabrication.
  - 1. Product Data: Include specifications, brochures, and samples.
- B. Certificates: Submit printed data to indicate compliance with following requirements.
  - 1. UL LISTING Verification and UL752 Current Test Results as provided by Underwriters Laboratories.
  - 2. ASTM E119-98 One-Hour Fire Rating of Building Construction and Materials.
  - 3. ASTM F1233-98 Standard Test Method for Forced Entry Testing of Materials/Assemblies.
  - 4. Manufacturer's third party certificate of registration with ISO 9001:2015.
  - 5. Manufacturer's U.S. Dept. of State ITAR Statement of Registration.

#### 1.4 DELIVERY, HANDLING, AND STORAGE

- A. Deliver materials to project with manufacturer's UL LISTED Labels intact and legible.
- B. Handle material with care to prevent damage. Store materials inside under cover, stack flat and off the floor.

#### 1.5 WARRANTY

- A. Warrant all materials and workmanship against defects for a period of ten (10) years from the date of Substantial Completion.

### PART 2 – PRODUCTS

## 2.1 MANUFACTURER

- A. Acceptable Manufacturer: Insulgard
- B. Acceptable Manufacturer: Armorcore
- C. Acceptable Manufacturer: Total Security Solutions
- D. Substitutions: Permitted.

## 2.2 PERFORMANCE CRITERIA

- A. Bullet Resistant Fiberglass Panels shall be “non ricochet type” to permit the encapture and retention of an attacking projectile lessening the potential of a random injury or lateral penetration.
- B. Panel Rating: UL752 Level 3.
- C. Bullet resistance of joints: equal to that of the panel.

## 2.3 MATERIALS

- A. Panels fabricated of multiple layers of woven roving ballistic grade fiberglass cloth impregnated with a thermoset polyester resin and compressed into flat rigid sheets.
- B. Thickness: 7/16” nominal thickness
- C. Nominal Weight: 4.8 lbs. per sq. ft.
- D. Available Panel Sizes: 3' x 8'

## PART 3 - EXECUTION

### 3.1 EXAMINATION

- A. Prior to starting installation, verify work of related trades required in contract documents and architectural drawings is complete to the point where work of this Section may properly commence.

### 3.2 JOINTS

- A. Reinforce joints with a back-up layer of bullet resistive material. Minimum width of reinforcing layer at joint shall be 4-inches, centered on panel joints.

### 3.3 APPLICATION

- A. Install in accordance with manufacturer’s printed recommendations and as required by contract documents.
- B. Secure armor panels using screws, bolts, or an industrial adhesive.
  - 1. Method of application shall install panels minimizing vulnerabilities by fitting tightly to adjacent surfaces including concrete floor slab, concrete roof slab, bullet resistive door frames, bullet resistive window frames, and the like.

END OF SECTION

## COMMON WORK RESULTS FOR FIRE SUPPRESSION – SECTION 13 90 00

### PART ONE GENERAL

#### 1.1 SECTION INCLUDES

- A. Pipe, fittings, valves, and connections for sprinkler systems.

#### 1.2 REFERENCE STANDARDS

- A. ASME B16.5 - Pipe Flanges and Flanged Fittings; The American Society of Mechanical Engineers; 2009 (ANSI/ASME B16.5).
- B. ASME B16.11 - Forged Steel Fittings, Socket-welding and Threaded; The American Society of Mechanical Engineers; 2009.
- C. ASME B16.18 - Cast Copper Alloy Solder Joint Pressure Fittings; The American Society of Mechanical Engineers; 2001 (R2005) (ANSI B16.18).
- D. ASME B36.10M - Welded and Seamless Wrought Steel Pipe; The American Society of Mechanical Engineers; 2004.
- E. AWS A5.8/A5.8M - Specification for Filler Metals for Brazing and Braze Welding; American Welding Society; 2004 and errata.
- F. NFPA 13 - Standard for the Installation of Sprinkler Systems; National Fire Protection Association; 2010.
- G. UL (FPED) - Fire Protection Equipment Directory; Underwriters Laboratories Inc.; current edition.
- H. UL 312 - Check Valves for Fire-Protection Service; Underwriters Laboratories Inc.; Current Edition, Including All Revisions.

#### 1.3 SUBMITTALS

- A. Refer to Division 01 requirements.
- B. Product Data: Provide manufacturers catalog information. Indicate valve data and ratings.
- C. Shop Drawings: Indicate pipe materials used, jointing methods, supports, floor and wall penetration seals. Indicate installation, layout, weights, mounting and support details, and piping connections.
- D. Project Record Documents: Record actual locations of components and tag numbering.
- E. Operation and Maintenance Data: Include installation instructions and spare parts lists.

#### 1.4 QUALITY ASSURANCE

- A. Manufacturer Qualifications: Company specializing in manufacturing the Products specified in this section with documented experience.
- B. Installer Qualifications: Company specializing in performing the work of this section with documented experience and approved by manufacturer.

- C. Valves: Bear UL label or marking. Provide manufacturer's name and pressure rating marked on valve body.
- D. Products Requiring Electrical Connection: Listed and classified as suitable for the purpose specified and indicated.

#### 1.5 CONTRACTOR COORDINATION

- A. Fire suppression contractor(s) shall coordinate their work with all other trades prior to fabrication of systems and commencement of installation. It shall be the responsibility of each contractor to review the work of other trades (including, but not limited to civil, structural, architectural, special equipment, fire alarm, plumbing, HVAC, and electrical) as it affects their work, and as their work affects other trades, to insure that the construction documents are closely followed. Where discrepancies arise, they shall be referred to the Architect/Engineer for resolution before proceeding with the Work.

#### 1.6 DELIVERY, STORAGE, AND HANDLING

- A. Deliver and store valves in shipping containers, with labelling in place.
- B. Provide temporary protective coating on cast iron and steel valves.
- C. Provide temporary end caps and closures on piping and fittings. Maintain in place until installation.

### PART TWO PRODUCTS

#### 2.1 FIRE PROTECTION SYSTEMS

- A. Sprinkler Systems: Conform work to NFPA 13.

#### 2.2 ABOVE GROUND PIPING

- A. Copper Tube: ASTM B 88 (ASTM B 88M), H58 drawn temper.
  1. Type: Type L (B).
  2. Fittings: ASME B16.18 or cast copper alloy solder joint, pressure type.
  3. Joints: AWS A5.8 Classification BCuP-3 or BCuP-4 copper/silver braze.

#### 2.3 PIPE HANGERS AND SUPPORTS

- A. Hangers for Pipe Sizes 1/2 to 1-1/2 inch: Malleable iron, adjustable swivel, split ring.
- B. Hangers for Pipe Sizes 2 inches and Over: Carbon steel, adjustable, clevis.
- C. Copper Pipe Support: Carbon steel ring, adjustable, copper plated.

#### 2.4 BUTTERFLY VALVES

- A. Bronze Body:
  1. Stainless steel disc, resilient replaceable seat, threaded or grooved ends, extended neck, handwheel and gear drive and integral indicating device , and built-in tamper proof switch rated 10 amp at 115 volt AC.
- B. Cast or Ductile Iron Body
  1. Cast or ductile iron, chrome or nickel plated ductile iron or aluminum bronze disc,

resilient replaceable EPDM seat, wafer, lug, or grooved ends, extended neck, handwheel and gear drive and integral indicating device , and internal tamper switch rated 10 amp at 115 volt AC.

## 2.5 CHECK VALVES

- A. Up to and including 2 inches:
  - 1. Bronze body and swing disc, rubber seat, threaded ends.

## PART THREE EXECUTION

### 3.1 PREPARATION

- A. Ream pipe and tube ends. Remove burrs. Bevel plain end ferrous pipe.
- B. Remove scale and foreign material, from inside and outside, before assembly.
- C. Prepare piping connections to equipment with flanges or unions.

### 3.2 INSTALLATION

- A. Install sprinkler system and service main piping, hangers, and supports in accordance with NFPA 13.
- B. Route piping in orderly manner, plumb and parallel to building structure. Maintain gradient.
- C. Install piping to conserve building space, to not interfere with use of space and other work.
- D. Group piping whenever practical at common elevations.
- E. Sleeve pipes passing through partitions, walls, and floors.
- F. Install piping to allow for expansion and contraction without stressing pipe, joints, or connected equipment.
- G. Pipe Hangers and Supports:
  - 1. Install hangers to provide minimum 1/2 inch space between finished covering and adjacent work.
  - 2. Place hangers within 12 inches of each horizontal elbow.
  - 3. Use hangers with 1-1/2 inch minimum vertical adjustment. Design hangers for pipe movement without disengagement of supported pipe.
  - 4. Provide copper plated hangers and supports for copper piping.
- H. Slope piping and arrange systems to drain at low points. Use eccentric reducers to maintain top of pipe level.
- I. Do not penetrate building structural members unless indicated.
- J. Install valves with stems upright or horizontal, not inverted. Remove protective coatings prior to installation.
- K. Provide butterfly valves for shut-off or isolating service.

- END OF SECTION -



Lineage Architects P.C. hereby expressly reserves its common law copyright and other property rights in these plans. These plans and drawings are not to be reproduced, changed or copied in any form or manner whatsoever without first obtaining the express written permission of Lineage Architects P.C. nor are they to be assigned to any third party without first obtaining written permission and consent.

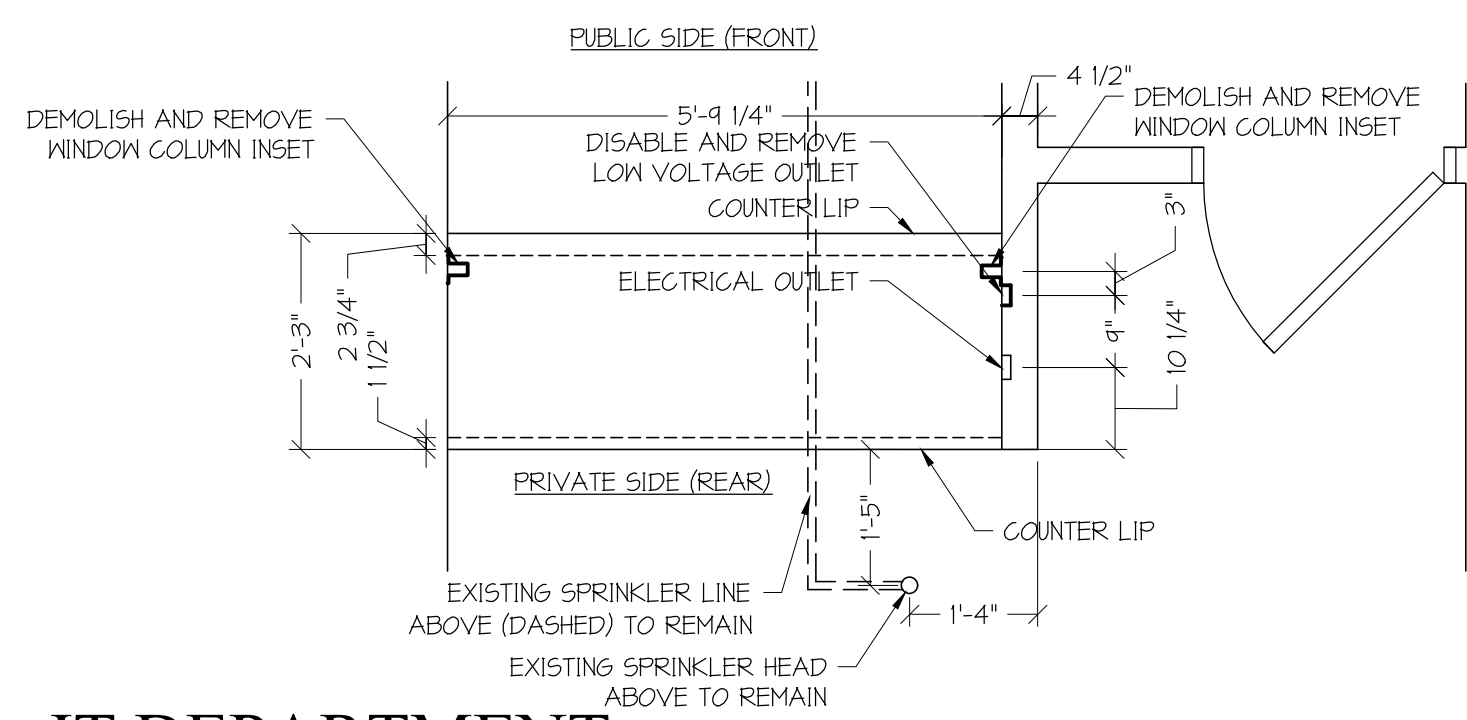

**IT DEPARTMENT  
EXISTING FLOOR PLAN**

SCALE: 1/2" = 1'-0"

1  
A1.1

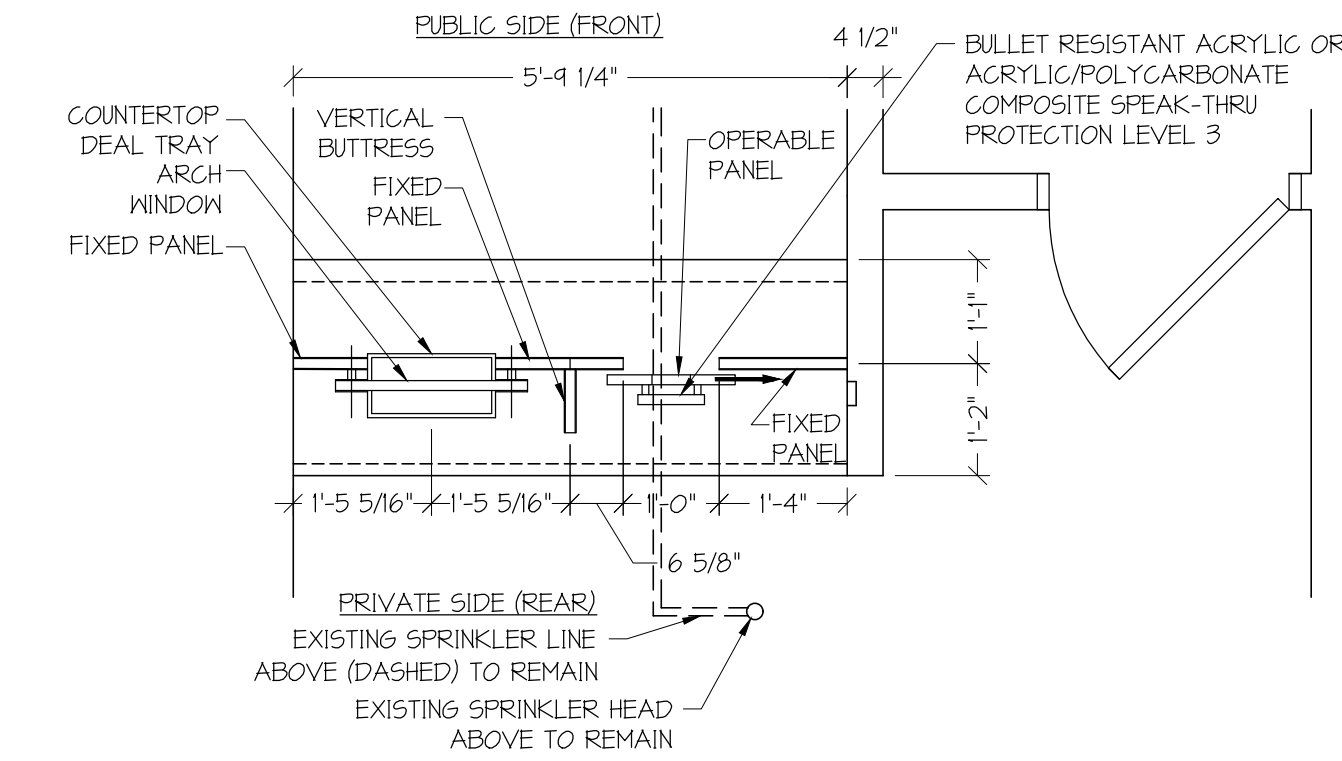

**IT DEPARTMENT  
NEW WORK FLOOR PLAN**

SCALE: 1/2" = 1'-0"

4  
A1.1

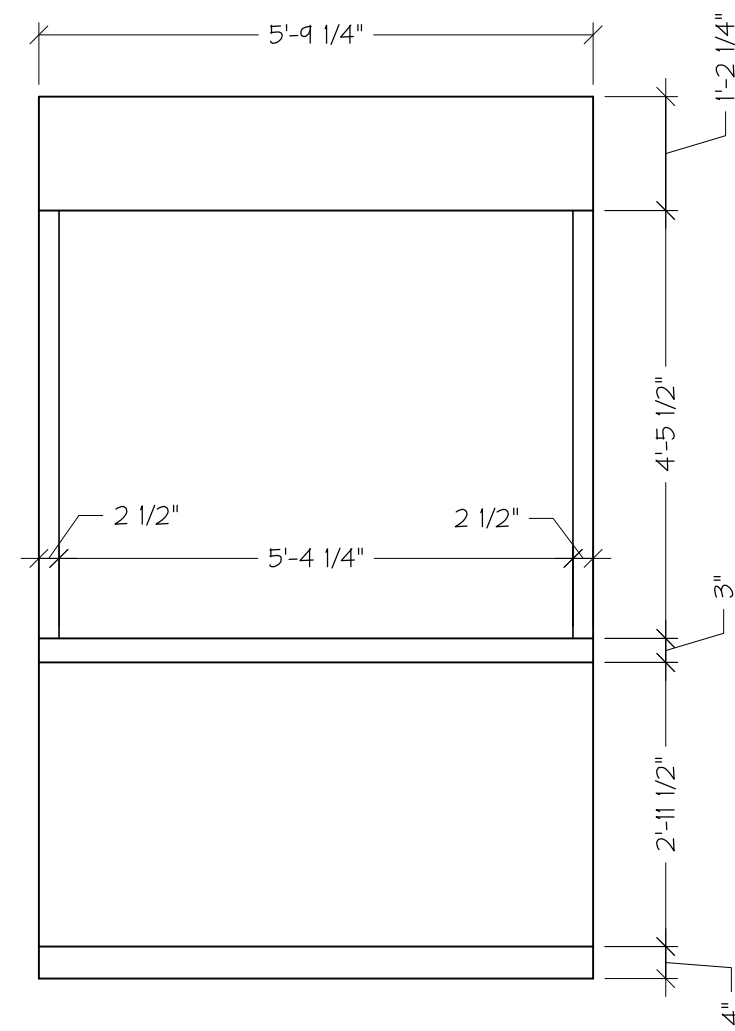

**IT DEPARTMENT  
EXISTING PUBLIC (FRONT) ELEVATION**

SCALE: 1/2" = 1'-0"

2  
A1.1

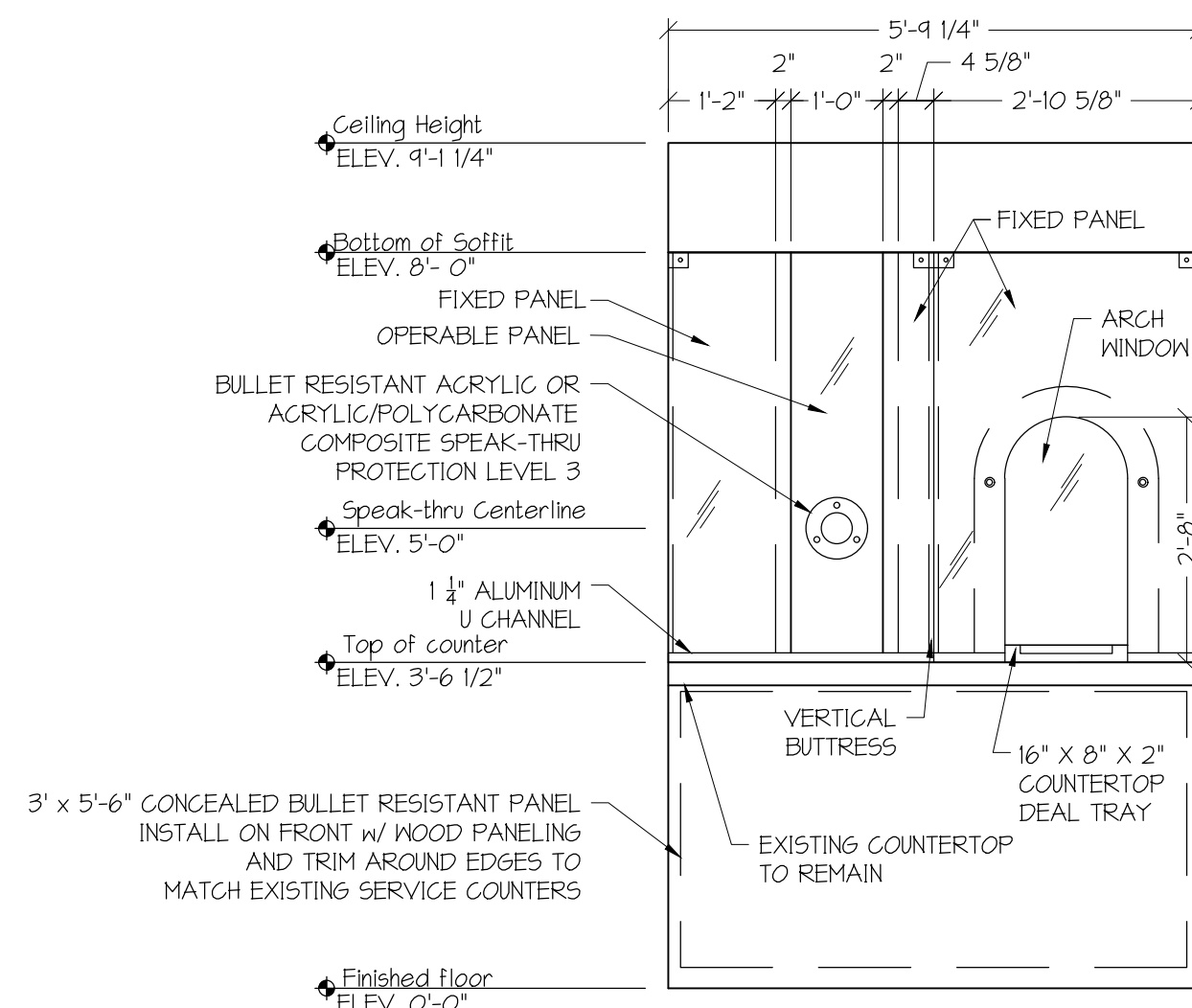

**IT DEPARTMENT  
NEW WORK PUBLIC (FRONT) ELEVATION**

SCALE: 1/2" = 1'-0"

5  
A1.1

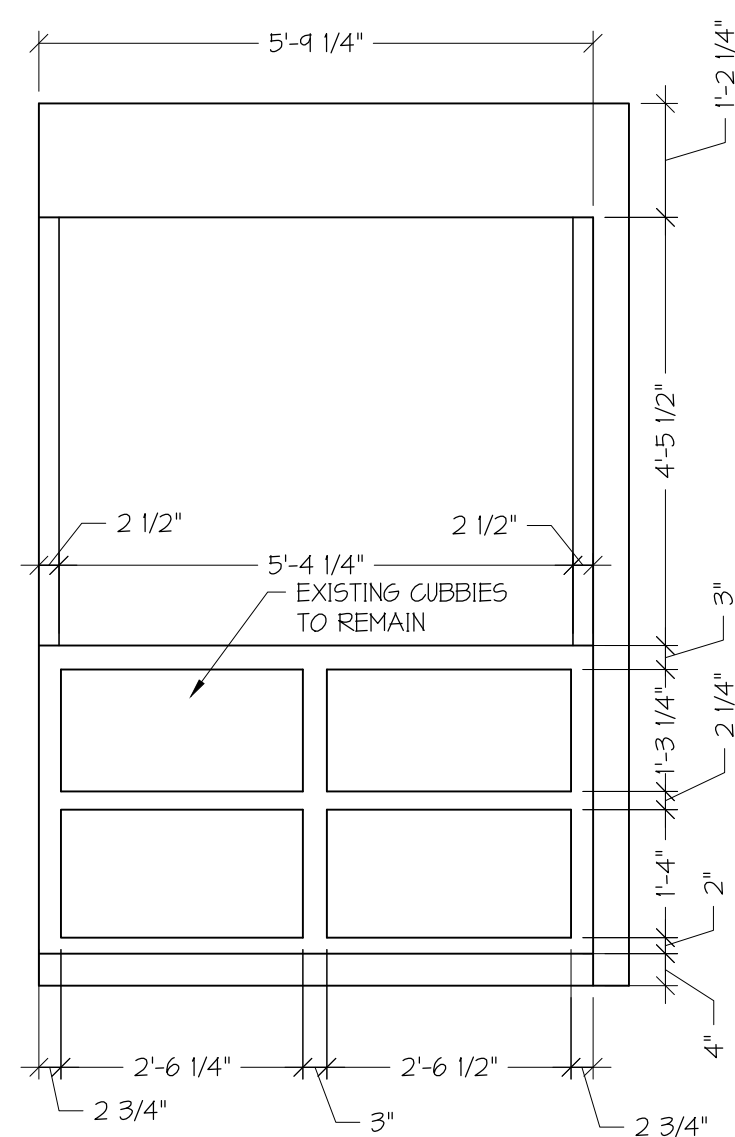

**IT DEPARTMENT  
EXISTING PRIVATE (REAR) ELEVATION**

SCALE: 1/2" = 1'-0"

3  
A1.1

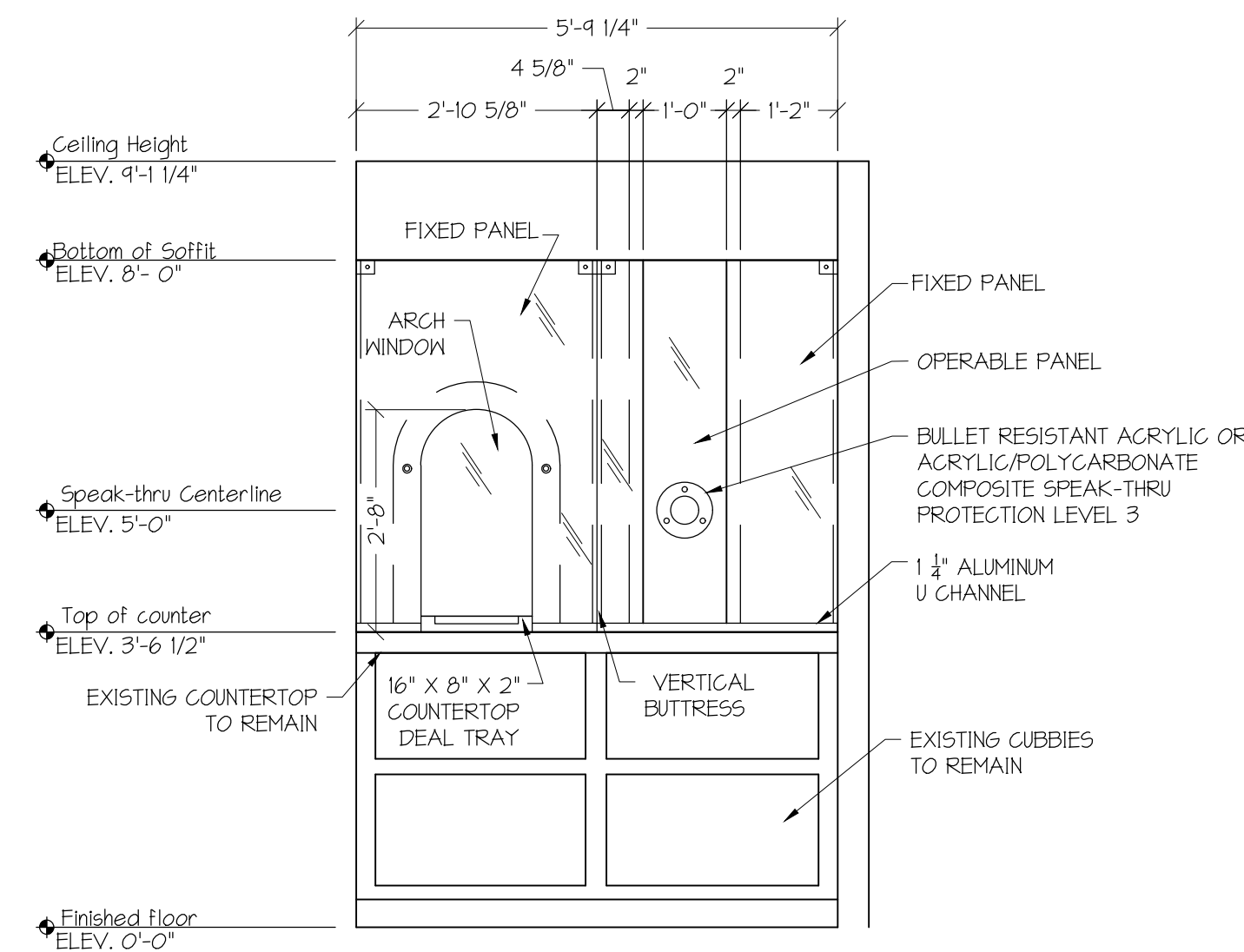

**IT DEPARTMENT  
NEW WORK PRIVATE (REAR) ELEVATION**

SCALE: 1/2" = 1'-0"

6  
A1.1

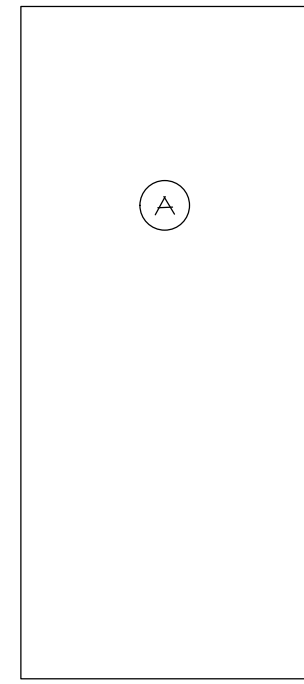

DOOR SCHEDULE										SYMBOL
DOOR LOCATION	TYPE	MATERIAL	DOOR SIZE			DOOR FINISH	THRESHOLD	HARDWARE TYPE	HARDWARE FINISH	NOTES
			W	H	T					
SECURITY OFFICE	A	STEEL	36"	80"	1 3/4"	WOOD VENEER	NONE	REUSE EXISTING	PER OWNER	HOLLOW CORE DOOR, INSTALL IN EXISTING HOLLOW METAL FRAME
REGISTRAR	A	STEEL	36"	80"	1 3/4"	PAINT	NONE	REUSE EXISTING	PER OWNER	HOLLOW CORE DOOR, INSTALL IN EXISTING HOLLOW METAL FRAME
BOARD ROOM	A	STEEL	36"	80"	1 3/4"	WOOD VENEER	NONE	REUSE EXISTING	PER OWNER	HOLLOW CORE DOOR, INSTALL IN EXISTING HOLLOW METAL FRAME

NOTES:  
1. SEE SPECIFICATIONS FOR ADDITIONAL INFORMATION.  
2. CONTRACTOR TO FIELD VERIFY DIMENSIONS OF EXISTING DOOR FRAMES BEFORE PURCHASING NEW DOORS.



**FIRM INFO:**  
Lineage Architects, P.C.  
P.O. Box 991  
98 Lee Highway  
Verona, VA 24482  
Phone: (540) 248-3771  
Fax: (540) 248-1628  
Email: info@lineagearch.com

**ENGINEER NAME/SEAL:**

**ARCHITECT NAME/SEAL:**

**PROJECT TITLE:**  
SECURITY IMPROVEMENTS  
**CLIENTS INFO:**  
AUGUSTA COUNTY GOVERNMENT  
18 GOVERNMENT CENTER LANE  
VERONA, VIRGINIA

NO.	REVISION/ISSUE	DATE
JOB NUMBER:		21050
DATE:		OCTOBER 29, 2021
DRAWN BY:		AMJ
APPROVED BY:		PZG

**DRAWING DESCRIPTION:**  
IT DEPARTMENT  
EXISTING CONDITIONS  
AND NEW WORK PLANS

**DRAWING NUMBER:**  
A1.1